

Diffuse contrast sensor

OZDM 16P1901/S14

dimension drawing

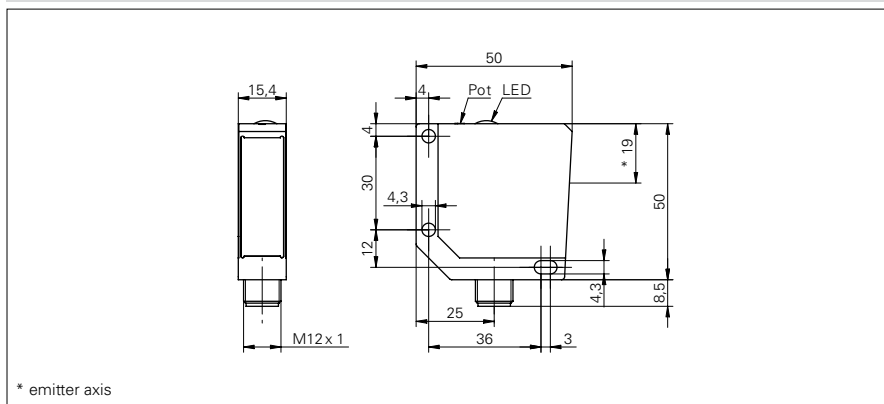

general data

type	diffuse contrast sensor
light source	pulsed red laser diode
sensing distance Tw	0 ... 250 mm
optimum operating distance	40 ... 80 mm
detectable remission difference (on grey)	> 8 %
repeat accuracy	< 0,1 mm at laser focus
output indicator	LED yellow
sensitivity adjustment	potentiometer, 14 turn
laser class	1
distance to focus	80 mm
wave length	650 nm

electrical data

response time / release time	< 0,1 ms
voltage supply range +Vs	12 ... 30 VDC
current consumption max.	65 mA
current consumption typ.	60 mA
voltage drop Vd	< 2 VDC
output function	light operate
output circuit	PNP / analog 4 ... 20 mA
output current	< 200 mA
short circuit protection	yes
reverse polarity protection	yes

mechanical data

width / diameter	15,4 mm
height / length	50 mm
depth	50 mm
type	rectangular
housing material	die-cast zinc
front (optics)	glass
connection types	connector M12 4 pin

ambient conditions

operating temperature	-10 ... +50 °C
protection class	IP 67

photo



connection diagram

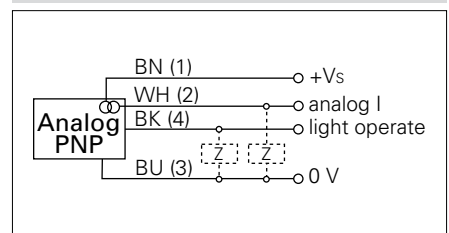

laser warning

